

Reliability assessment of complex system consisting two subsystems connected in series configuration using Gumbel-Hougaard family copula distribution

Kabiru H. Ibrahim¹, V. V. Singh² and Abdul Kareem Lado³

Abstract

This paper focused on the study of reliability measures of the complex system consist of two subsystems, (subsystem-1 and subsystem-2), both connected in series. Subsystem-1 has four units in a parallel configuration and working under 2-out-of-4: G; policy. The subsystem-2 has one unit; both the subsystems are connected in a series configuration. The system has three types of failure, minor partial failure, major partial failure, and complete failure. It is assumed that the minor and major partial failures bring the system in the degraded state, while the complete failure mode stops working of the system. All failure rates are constant

¹ Department of Mathematics, Kano University of Science & Technology, Wudil, Kano, Nigeria. E-mail: kbrhamis032@gmail.com

² Department of Mathematics Yusuf Maitama Sule University, Kano, Nigeria.
E-mail: singh_vijayvir@yahoo.com

³ Department of Mathematics, Kano University of Science & Technology, Wudil, Kano, Nigeria. E-mail: ladgetso@gmail.com.

and assumed to follow an exponential distribution, but the repair follows two types of distribution, general distribution, and Gumbel-Hougaard family copula (Joint probability distribution). The system is analyzed by employing supplementary variable and Laplace transform. The various measures of system reliability such as Availability, Reliability, and Mean time to failure (MTTF), profit analysis have been obtained. Critical examinations of the system have been made throughout the work. The computed results have been demonstrated by graph and utility of analysis have been conveyed through conclusion section.

Mathematics Subject Classification: 62N05; 60K05

Keywords: Availability; Reliability; Sensitivity; Mean time to system failure (MTTF); Gumbel-Hougaard family copula; Supplementary variables

1 Introduction

Repairable systems usually have studied concerning the evaluation of the performance of reliability measures regarding availability, reliability, mean-time to system failure (MTSF) and cost benefits in operation of the prescribed system. In the past, the several studies on reliability assessments of the complex system have done by various researchers and scientists. In the current scenario of the competitive trend of business situation, everyone expects to purchase a product which can meet the changes in future perspectives. A lot of work has been done in the improvement of reliability in composing the components in series, parallel and k-out-of-n configuration. Referred to the study of repairable systems, Alka et al. [1] analyzed the reliability of the complex repairable system which comprises a, 2-out-of-3: G subsystem connected in a parallel configuration. Singh et al. [2] have studied the performance analysis of the complex system in the series configuration under different types of failure and repairs using copula. Chung et al. [3] have studied reliability and performance of the k-out-of-n redundant system with the

presences of chance with multiple critical errors. Dillon et al. [4] have discussed the common cause's failure analysis of k-out-of-n: G systems which consisting repairable units. Goel et al. [5] studied the performance of systems with two types of failure and pre-emptive maintenance repair. Jain et al. [6] analyze the reliability, availability and cost assessment of a 1-out-of-n, systems which are an equivalent to a simple of series configuration in an N unit system. Ibrahim Yusuf [7] evaluates the performance of a repairable system with the concept of minor deterioration under imperfect repair. Minjae Park [8] analyzed the multi-component system with imperfect repair during warranty using renewal process. Deepak Kumar and S. B. Singh [9] have investigated a complex repairable system with deliberate failure emphasizing reboot delay. M. S. Kadyan et al. [10] have studied probabilistic analysis of two reliability model the single unit system with preventive maintenance beyond warranty and degradation assumption.

V.V. Singh et al. [11] have analyzed the reliability parameters and evaluated the performance of a repairable system which has three units at super priority, priority and ordinary under primitive resume repair policy using different types of failure and two types of repair. V. V. Singh and Mangey Ram, [12] have studied Multi-state k-out-of-n type repairable system analysis with particular emphasized 2- out-of -3 case for computations and results demonstrations. Rawal et al. [13], studied reliability measures of internet data center with various maintenance policies. Singh and Dalah [14] have examined the reliability measures of a two-unit standby redundant system under the concept of switch failure using Gumbel-Hougaard family Copula Distribution. Tseng- Chang Yen et al. [15] studied Reliability and sensitivity analysis of the controllable repair system with warm standbys and working breakdown.

In the past the mainly the authors focused their study of complex repairable systems using general repair policy. Consequent to the previous study of the repairable systems it had supposed that the adjacent failed one type of repair can restore states of the system. There are many situations in real life which need

urgent repair, i.e. more than one repair for quick maintenance of repairable systems. In this concern the authors have brought their attentions toward the study of complex repairable systems using more than one repair is possible between two adjacent states. When such possible exit the system is repaired using copula [16]. The copula distributions which couple's different types of distribution play a crucial role in the study of complex repairable systems. The authors have employed the various types of copula for the study of the complex repairable system but Gumbel – Hougaard family copula is simple which couples two types of distribution, i.e. (General distribution and Exponential distribution). In the present study, the authors have employed Gumbel-Hougaard family copula for computations and demonstrations.

In the present paper, we have analyzed a complex system with two subsystems (Subsystem-A & subsystem -B). The Subsystem-A is connected in parallel and working under 2-out-of-4: G, policy and the subsystem-2 have a single unit, both subsystems are connected in a series configuration. Initially, in state S_0 , the system is in good working condition. After failure of any one unit in subsystem -1, the system approaches the states S_1 , S_3 , S_7 , and S_9 (minor partial failure/degraded states), similarly after failure of two units in subsystem-A the system will be in state S_2 , S_4 , S_8 , and S_{10} (major partial failure/degraded states). The system will be in complete failure at states S_5 , S_6 , S_{11} , and S_{12} . The system has analyzed using supplementary variable and Laplace transform, and the computed results have demonstrated by tables and graphs.

The paper has studied in following sections. In section I, we have reviewed the related work presented by varies researchers and titled it as the introduction of the model. The section II of the paper consists state description, assumptions, notations, system configuration and state transition diagram of the model mathematical modeling and solution of the formulated model using a supplementary variable and Laplace transform. The section III elaborate analytical part of the model with evaluations of various reliability parameters such as; Availability, Reliability,

Sensitivity analysis of MTTF, a variation of MTTF (Mean time to failure) and Cost/ profit analysis by assigning different values of the failure and repair rates. Finally, in section IV, we have concluded our study.

2 State Description, Notation, and assumptions

2.1 Description of The States

Table 1: Description of The State Model

State	State Description
S_0	The state S_0 represents a perfect state in which both the subsystems are in good working condition.
S_1	The state S_1 represents a degraded state with minor partial failure in the subsystem-1 due to the failure of the first unit of the subsystem-1.
S_2	This state accounts for a degraded state with major partial failure in the subsystem-1 due to the failure of first and second units of the subsystem-1.
S_3	The state S_3 represent a minor partial failure due to the failure of the third unit of subsystem-1.
S_4	This state represents a degraded state with major partial failure, due to the failure of third and fourth units of the subsystem-1. The system is under repair and elapses repair time lies in $(x, x + \Delta x)$.
S_5	The state S_5 represent a complete failed state, due to failure of first, second and third units in the subsystem-1, and failure of subsystem-2, the system is under repair using copula
S_6	The state S_6 represent a complete failed state, due to failure of first, third, and fourth units in the subsystem-1 and failure of subsystem-2, the system

	is under repair using copula
S_7	The state S_3 represent a minor partial failure due to the inability of the fourth unit of subsystem-1.
S_8	This state accounts for a degraded state with major partial failure, due to the failure of second and fourth units of the subsystem-1. The system is under repair and elapses repair time lies in $(x, x + \Delta x)$.
S_9	The state S_3 represent a minor partial failure due to failure of the second unit of subsystem-1
S_{10}	The state S_{10} accounts for a degraded state with major partial failure, due to the failure of second and third units of the subsystem-1. The system is under repair and elapses repair time lies in $(x, x + \Delta x)$.
S_{11}	This state represents a complete partial failure due to the failure of second, third and fourth units of subsystem-1 and failure of subsystem-2.
S_{12}	This state represents a complete partial failure due to the failure of second, third and fourth units of subsystem-1 and failure of subsystem-2.

The state description highlight that S_0 is a state where the system is in a perfect state where both subsystems are in good working condition. S_1 , S_3 , S_7 , and S_9 are the states where the system is in minor partial failure but operational mode. The states S_2 , S_4 , S_8 , S_{10} are in major partial failure in which the system is working under the critical stage, and further failure in any unit in the subsystem-1 might be a cause of complete failure. The states S_5 , S_6 , S_{11} , and S_{12} , are the failed state of the model. The minor and major failed states will be respire by employing general repair, but the complete failed state will be restored using Gumbel- Hougaard family copula distribution.

2.2 Assumptions

The following assumption is taken throughout the discussion of the model:

- Initially, the system is in S_0 state, and all units of the system are in good working condition.
- The system works successfully when all units of Subsystem-A are good condition together with the Subsystem-B.
- The system fails if the subsystem-2 fails or both two subsystems fail.
- The minor/major partial failed states of the system are repaired by employing the general distribution, but the entire failed states are restored by using Gumbel-Hougaard family copula distribution.
- As soon as the system repaired, it starts working, and repair does not damage anything.
- The repaired system works as a new and repair do not affect the efficiency of the system.
- All failure rates are constants and follow a negative exponential distribution.

2.3 Notations

Table 2: Notations

$t :$	Time variable on time scale.
$s :$	Laplace transform variable for all expressions.
$\lambda_1 / \lambda_2 / \lambda_3 / \lambda_4 :$	Failure rates of units of subsystem-A.
$\lambda_5 :$	Failure rates of unit 5 of subsystem-B.
$\phi_1(x), \phi_2(x),$ $\phi_3(x), \phi_4(x) :$	Repair rates for the units 1, 2, 3 and 4 of the subsystem-A.
$\mu_0(x), \mu_0(y) :$	Repair rates for complete failed states.

$P_i(x, t) :$	The probability that the system is in S_i state at instant's' for $i = 0$ to 12.
$\bar{P}(s) :$	Laplace transformation of testate transition probability $P(t)$.
$E_p(t) :$	Expected profit during the time interval $[0, t)$.
$K_1, K_2:$	Revenue and service cost per unit time in the interval $[0, t)$ respectively.
$S_\varphi(x) :$	$S_\varphi(x) = \varphi(x) e^{-\int_0^x \varphi(x) dx}$ with repair distribution function $\varphi(x)$.
$L[S_\varphi(x)] :$	$\int_0^\infty e^{-sx} \varphi(x) e^{-\int_0^x \varphi(x) dx} dx = \bar{S}_\varphi(s)$, is the Laplace transform of $S_\varphi(x)$
$L\left[\frac{1-S_\varphi(x)}{s}\right] :$	$\int_0^\infty e^{-sx} e^{-\int_0^x \varphi(x) dx} dx = \frac{1-\bar{S}_\varphi(s)}{s}$ is the Laplace transform of $\frac{1-\bar{S}_\varphi(x)}{s}$
$\mu_0(x) = C_\theta(u_1(x), u_2(x)):$	The expression of joint probability (failed state S_i to good state S_0) according to Gumbel-Hougaard family copula is given as $C_\theta(u_1(x), u_2(x)) = \exp[x^\theta + \{\log \phi(x)\}^\theta]^{1/\theta}$, where, $u_1 = \phi(x)$, and $u_2 = e^x$, where θ as a parameter, $1 \leq \theta \leq \infty$.

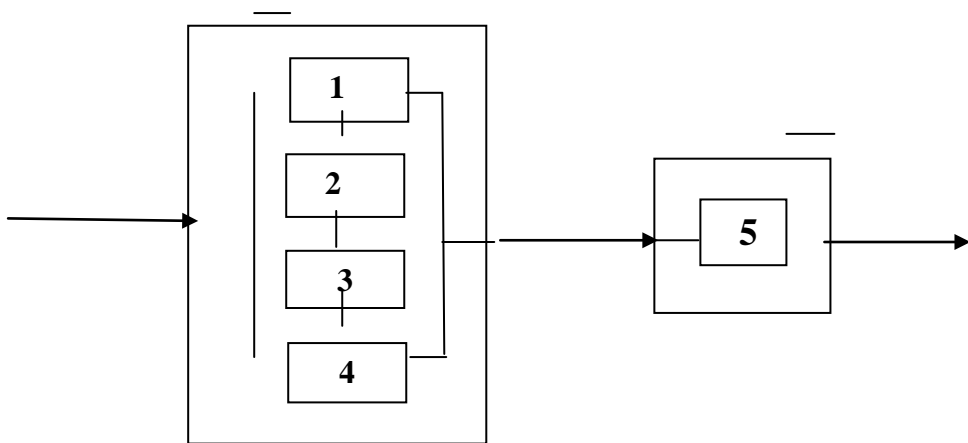

Figure 1: System configuration

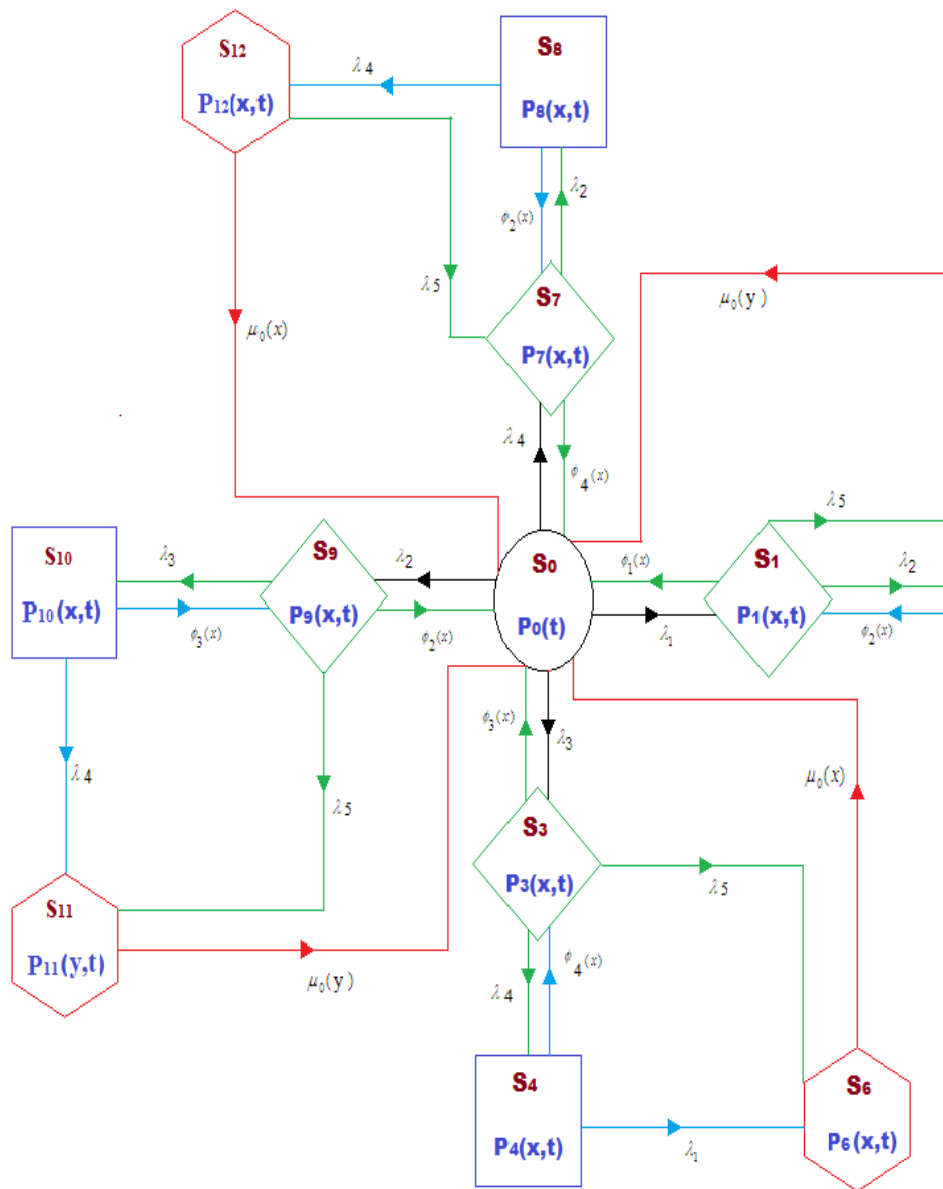

Figure 2: State Transition diagram of Model

3 Formulation of the mathematical model

By the probability of considerations and continuity arguments, the following set of difference differential equations are associated with the present mathematical model.

$$\begin{aligned} & \left[\frac{\partial}{\partial t} + \lambda_1 + \lambda_2 + \lambda_3 + \lambda_4 + \lambda_5 \right] P_0(t) = \\ & = \int_0^{\infty} \varphi_1(x) P_1(x, t) dx + \int_0^{\infty} \varphi_2(x) P_9(x, t) dx + \int_0^{\infty} \varphi_3(x) P_3(x, t) dx + \int_0^{\infty} \varphi_4(x) P_7(x, t) dx + \\ & + \int_0^{\infty} \mu_0(y) P_5(y, t) dy + \int_0^{\infty} \mu_0(x) P_6(x, t) dx + \int_0^{\infty} \mu_0(y) P_{11}(y, t) dy + \int_0^{\infty} \mu_0(x) P_{12}(x, t) dx \end{aligned} \quad (1)$$

$$\left[\frac{\partial}{\partial t} + \frac{\partial}{\partial x} + \lambda_2 + \lambda_5 + \varphi_1(x) \right] P_1(x, t) = 0 \quad (2)$$

$$\left[\frac{\partial}{\partial t} + \frac{\partial}{\partial x} + \lambda_3 + \varphi_2(x) \right] P_2(x, t) = 0 \quad (3)$$

$$\left[\frac{\partial}{\partial t} + \frac{\partial}{\partial x} + \lambda_4 + \lambda_5 + \varphi_3(x) \right] P_3(x, t) = 0 \quad (4)$$

$$\left[\frac{\partial}{\partial t} + \frac{\partial}{\partial x} + \lambda_1 + \varphi_4(x) \right] P_4(x, t) = 0 \quad (5)$$

$$\left[\frac{\partial}{\partial t} + \frac{\partial}{\partial y} + \mu_0(y) \right] P_5(y, t) = 0 \quad (6)$$

$$\left[\frac{\partial}{\partial t} + \frac{\partial}{\partial x} + \mu_0(x) \right] P_6(x, t) = 0 \quad (7)$$

$$\left[\frac{\partial}{\partial t} + \frac{\partial}{\partial x} + \lambda_2 + \lambda_5 + \varphi_4(x) \right] P_7(x, t) = 0 \quad (8)$$

$$\left[\frac{\partial}{\partial t} + \frac{\partial}{\partial x} + \lambda_1 + \varphi_2(x) \right] P_8(x, t) = 0 \quad (9)$$

$$\left[\frac{\partial}{\partial t} + \frac{\partial}{\partial x} + \lambda_3 + \lambda_5 + \varphi_2(x) \right] P_9(x, t) = 0 \quad (10)$$

$$\left[\frac{\partial}{\partial t} + \frac{\partial}{\partial x} + \lambda_4 + \varphi_3(x) \right] P_{10}(x, t) = 0 \quad (11)$$

$$\left[\frac{\partial}{\partial t} + \frac{\partial}{\partial y} + \mu_0(y) \right] P_{11}(y, t) = 0 \quad (12)$$

$$\left[\frac{\partial}{\partial t} + \frac{\partial}{\partial x} + \mu_0(x) \right] P_{12}(x, t) = 0 \quad (13)$$

BOUNDARY CONDITIONS

$$P_1(0, t) = \lambda_1 P_0(t) + \int_0^{\infty} \varphi_2(x) P_2(x, t) dx \quad (14)$$

$$P_2(0, t) = \lambda_2 [\lambda_1 P_0(t) + \int_0^{\infty} \varphi_2(x) P_2(x, t) dx] \quad (15)$$

$$P_3(0, t) = \lambda_3 P_0(t) + \int_0^{\infty} \varphi_4(x) P_4(x, t) dx \quad (16)$$

$$P_4(0, t) = \lambda_4 [\lambda_3 P_0(t) + \int_0^{\infty} \varphi_4(x) P_4(x, t) dx] \quad (17)$$

$$P_5(0, t) = \lambda_3 P_2(0, t) + \lambda_5 P_1(0, t) + \lambda_5 P_0(t) \quad (18)$$

$$P_6(0, t) = \lambda_1 P_4(0, t) + \lambda_5 P_3(0, t) \quad (19)$$

$$P_7(0, t) = \lambda_4 P_0(t) + \int_0^{\infty} \varphi_2(x) P_8(0, t) dx \quad (20)$$

$$P_8(0, t) = \lambda_2 P_7(0, t) \quad (21)$$

$$P_9(0, t) = \lambda_2 P_0(t) + \int_0^{\infty} \varphi_3(x) P_{10}(0, t) dx \quad (22)$$

$$P_{10}(0, t) = \lambda_3 P_9(0, t) \quad (23)$$

$$P_{11}(0, t) = \lambda_4 P_{10}(0, t) + \lambda_5 P_9(0, t) \quad (24)$$

$$P_{12}(0,t) = \lambda_1 P_8(0,t) + \lambda_5 P_7(0,t) \quad (25)$$

Initial conditions

$$P_0(0) = 1 \text{ and other state probabilities are zero } t=0. \quad (26)$$

3.1 Solution of The Model:

Taking Laplace transformation of equations (1) -(13) with the help of initial condition, $P_0(0) = 1$, one can obtain.

$$\begin{aligned} [s + \lambda_1 + \lambda_2 + \lambda_3 + \lambda_4 + \lambda_5] \bar{P}_0(s) = \\ = 1 + \int_0^\infty \varphi_1(x) \bar{P}_1(x,s) dx + \int_0^\infty \varphi_2(x) \bar{P}_9(x,s) dx + \int_0^\infty \varphi_3(x) \bar{P}_3(x,s) dx + \\ + \int_0^\infty \varphi_4(x) \bar{P}_7(x,t) dx + \int_0^\infty \mu_0(y) \bar{P}_5(y,s) dy + \int_0^\infty \mu_0(x) \bar{P}_6(x,s) dx + \\ + \int_0^\infty \mu_0(y) \bar{P}_{11}(y,s) dy + \int_0^\infty \mu_0(x) \bar{P}_{12}(x,t) dx \end{aligned} \quad (27)$$

$$\left[s + \frac{\partial}{\partial x} + \lambda_2 + \lambda_5 + \varphi_1(x) \right] \bar{P}_1(x,s) = 0 \quad (28)$$

$$\left[s + \frac{\partial}{\partial x} + \lambda_3 + \varphi_2(x) \right] \bar{P}_2(x,s) = 0 \quad (29)$$

$$\left[s + \frac{\partial}{\partial x} + \lambda_4 + \lambda_5 + \varphi_3(x) \right] \bar{P}_3(x,s) = 0 \quad (30)$$

$$\left[s + \frac{\partial}{\partial x} + \lambda_1 + \varphi_4(x) \right] \bar{P}_4(x,s) = 0 \quad (31)$$

$$\left[s + \frac{\partial}{\partial y} + \mu_0(y) \right] \bar{P}_5(y,s) = 0 \quad (32)$$

$$\left[s + \frac{\partial}{\partial x} + \mu_0(x) \right] \bar{P}_6(x,s) = 0 \quad (33)$$

$$\left[s + \frac{\partial}{\partial x} + \lambda_2 + \lambda_5 + \varphi_4(x) \right] \bar{P}_7(x, s) = 0 \quad (34)$$

$$\left[s + \frac{\partial}{\partial x} + \lambda_1 + \varphi_2(x) \right] \bar{P}_8(x, s) = 0 \quad (35)$$

$$\left[s + \frac{\partial}{\partial x} + \lambda_3 + \lambda_5 + \varphi_2(x) \right] \bar{P}_9(x, s) = 0 \quad (36)$$

$$\left[s + \frac{\partial}{\partial x} + \lambda_4 + \varphi_3(x) \right] \bar{P}_{10}(x, s) = 0 \quad (37)$$

$$\left[s + \frac{\partial}{\partial y} + \mu_0(y) \right] P_{11}(y, s) = 0 \quad (38)$$

$$\left[s + \frac{\partial}{\partial x} + \mu_0(x) \right] P_{12}(x, s) = 0 \quad (39)$$

Laplace transform of boundary conditions

$$\bar{P}_1(0, s) = \lambda_1 \bar{P}_0(s) + \int_0^{\infty} \varphi_2(x) P_2(0, s) dx \quad (40)$$

$$\bar{P}_2(0, s) = \lambda_1 \lambda_2 \bar{P}_0(s) + \lambda_2 \int_0^{\infty} \varphi_2(x) \bar{P}_2(0, s) dx \quad (41)$$

$$\bar{P}_3(0, s) = \lambda_3 \bar{P}_0(s) + \int_0^{\infty} \varphi_4(x) \bar{P}_4(0, s) dx \quad (42)$$

$$\bar{P}_4(0, s) = \lambda_4 \bar{P}_3(0, s) \quad (43)$$

$$\bar{P}_5(0, s) = [\lambda_1 \lambda_2 \lambda_3 + \lambda_1 \lambda_5 + \lambda_5] \bar{P}_0(s) + \int_0^{\infty} \varphi_2(x) \bar{P}_2(0, s) dx \quad (44)$$

$$\bar{P}_6(0, s) = [\lambda_1 \lambda_2 + \lambda_5] \bar{P}_3(0, s) \quad (45)$$

$$\bar{P}_7(0, s) = \lambda_4 \bar{P}_0(s) + \int_0^{\infty} \varphi_2(x) \bar{P}_8(0, s) dx \quad (46)$$

$$\bar{P}_8(0, s) = \lambda_2 \bar{P}_7(0, s) \quad (47)$$

$$\bar{P}_9(0, s) = \lambda_2 \bar{P}_0(s) + \int_0^{\infty} \varphi_3(x) \bar{P}_{10}(0, s) dx \quad (48)$$

$$\bar{P}_{11}(0, s) = [\lambda_3 \lambda_4 + \lambda_4] \bar{P}_9(0, s) \quad (49)$$

$$\bar{P}_{12}(0, s) = [\lambda_3 \lambda_4 + \lambda_4] \bar{P}_7(0, s) \quad (50)$$

Solving (28) -(39), with help of equations (40) to (50) one may get;

$$\bar{P}_0(s) = \frac{1}{D(s)} \quad (51)$$

$$\bar{P}_1(s) = \frac{\lambda_1}{D(s)} \frac{1 - \bar{S}_{\varphi_1}(s + \lambda_2 + \lambda_5)}{(1 - \lambda_2 \bar{S}_{\varphi_2}(s + \lambda_3))(s + \lambda_2 + \lambda_5)} \quad (52)$$

$$\bar{P}_2(s) = \frac{(\lambda_1 \lambda_2)}{D(s)} \frac{1 - \bar{S}_{\varphi_2}(s + \lambda_3)}{(1 - \lambda_2 \bar{S}_{\varphi_2}(s + \lambda_3))(s + \lambda_3)} \quad (53)$$

$$\bar{P}_3(s) = \frac{\lambda_3}{D(s)} \frac{1 - \bar{S}_{\varphi_4}(s + \lambda_4 + \lambda_5)}{(1 - \lambda_4 \bar{S}_{\varphi_4}(s + \lambda_4 + \lambda_5))(s + \lambda_4 + \lambda_5)} \quad (54)$$

$$\bar{P}_4(s) = \frac{\lambda_3 \lambda_4}{D(s)} \frac{1 - \bar{S}_{\varphi_4}(s + \lambda_4)}{(1 - \lambda_4 \bar{S}_{\varphi_4}(s + \lambda_4 + \lambda_5))s + \lambda_4} \quad (55)$$

$$\bar{P}_5(s) = \frac{(\lambda_1 \lambda_2 \lambda_3 + \lambda_1 \lambda_5 + \lambda_5)}{D(s)} \frac{1 - \bar{S}_{\mu_0}(s)}{(1 - \lambda_2 \bar{S}_{\varphi_2}(s + \lambda_3))(s)} \quad (56)$$

$$\bar{P}_6(s) = \frac{\lambda_3(\lambda_1 \lambda_2 + \lambda_5)}{D(s)} \frac{1 - \bar{S}_{\mu_0}(s)}{(1 - \lambda_4 \bar{S}_{\varphi_4}(s + \lambda_4 + \lambda_5))s} \quad (57)$$

$$\bar{P}_7(s) = \frac{\lambda_4}{D(s)} \frac{1 - \bar{S}_{\varphi_2}(s + \lambda_1)}{(1 - \lambda_2 \bar{S}_{\varphi_2}(s + \lambda_1))(s + \lambda_1)} \quad (58)$$

$$\bar{P}_8(s) = \frac{\lambda_2 \lambda_4}{D(s)} \frac{1 - \bar{S}_{\varphi_4}(s + \lambda_1)}{(1 - \lambda_2 \bar{S}_{\varphi_2}(s + \lambda_1))(s + \lambda_1)} \quad (59)$$

$$\bar{P}_9(s) = \frac{\lambda_2}{D(s)} \frac{1 - \bar{S}_{\varphi_4}(s + \lambda_3 + \lambda_5)}{(1 - \lambda_3 \bar{S}_{\varphi_2}(s + \lambda_4))(s + \lambda_3 + \lambda_5)} \quad (60)$$

$$\bar{P}_{10}(s) = \frac{\lambda_1 \lambda_2}{D(s)} \frac{1 - \bar{S}_{\mu_0}(s + \lambda_4)}{(1 - \lambda_3 \bar{S}_{\varphi_2}(s + \lambda_4))(s + \lambda_4)} \quad (61)$$

$$\bar{P}_{11}(s) = \frac{\lambda_2 (\lambda_3 \lambda_4 + \lambda_5)}{D(s)} \frac{1 - \bar{S}_{\mu_0}(s)}{(1 - \lambda_3 \bar{S}_{\varphi_2}(s + \lambda_3))s} \quad (62)$$

$$\bar{P}_{12}(s) = \frac{\lambda_4 (\lambda_1 \lambda_2 + \lambda_5)}{D(s)} \frac{1 - \bar{S}_{\mu_0}(s)}{(1 - \lambda_2 \bar{S}_{\varphi_2}(s + \lambda_1))s} \quad (63)$$

Where,

$$D(s) = (s + \lambda_1 + \lambda_2 + \lambda_3 + \lambda_4 + \lambda_5) \left\{ \left[\frac{\lambda_1 \varphi_1 (s + \lambda_3 + \varphi_2)}{(s + \lambda_2 + \lambda_5 + \varphi_1)(s + \lambda_3 + \varphi_2 - \lambda_2 \varphi_2)} \right] + \left[\frac{\lambda_2 \varphi_2 (s + \lambda_4 + \varphi_3)}{(s + \lambda_3 + \lambda_5 + \varphi_3)(s + \lambda_4 + \varphi_4 - \lambda_2 \varphi_3)} \right] + \left[\frac{\lambda_3 \varphi_3 (s + \lambda_1 + \varphi_4)}{(s + \lambda_4 + \lambda_5 + \varphi_3)(s + \lambda_1 + \varphi_4 - \lambda_4 \varphi_4)} \right] \right\} \\ + \left[\frac{\lambda_4 \varphi_4 (s + \lambda_1 + \varphi_2)}{(s + \lambda_2 + \lambda_5 + \varphi_4)(s + \lambda_1 + \varphi_2 - \lambda_2 \varphi_2)} \right] + \left[\frac{\lambda_5 \mu_0 (s + \lambda_1 + \varphi_4) (\lambda_1 \lambda_4 + \lambda_5)}{(s + \mu_0)(s + \lambda_1 + \varphi_4 - \lambda_4 \varphi_4)} \right] + \left[\frac{\lambda_1 \mu_0 (s + \lambda_3 + \varphi_2) (\lambda_2 \lambda_5 + \lambda_5) + \lambda_5}{(s + \mu_0)(s + \lambda_1 + \varphi_4 - \lambda_4 \varphi_4)} \right] \\ + \left[\frac{\lambda_2 \mu_0 (s + \lambda_4 + \varphi_3) (\lambda_3 \lambda_4 + \lambda_5)}{(s + \mu_0)(s + \lambda_4 + \varphi_3 - \lambda_3 \varphi_3)} \right] + \left[\frac{\lambda_4 \mu_0 (s + \lambda_1 + \varphi_2) (\lambda_1 \lambda_2 + \lambda_5)}{(s + \mu_0)(s + \lambda_1 + \varphi_2 - \lambda_2 \varphi_2)} \right]$$

The Laplace transformations of the state transition probabilities that the system is in operational mode (i.e., either good or degraded state) and failed state at any time is as follows:

$$\bar{P}_{up}(s) = \bar{P}_0(s) + \bar{P}_1(s) + \bar{P}_2(s) + \bar{P}_3(s) + \bar{P}_4(s) + \bar{P}_7(s) + \bar{P}_8(s) + \bar{P}_9(s) + \bar{P}_{10}(s)$$

$$P_{up}(s) = \frac{1}{D(s)} \left\{ \left[\frac{\lambda_1 (s + \lambda_3 + \varphi_2)}{(s + \lambda_2 + \lambda_5 + \varphi_1)(s + \lambda_3 + \varphi_2 + \lambda_3 \varphi_2)} \right] + \left[\frac{\lambda_1 \lambda_2 (s + \lambda_3 + \varphi_2)}{(s + \lambda_3 + \lambda_4 + \varphi_1)(s + \lambda_3 + \varphi_2 + \lambda_2 \varphi_2)} \right] + \left[\frac{\lambda_3 (s + \lambda_1 + \varphi_4)}{(s + \lambda_4 + \lambda_5 + \varphi_3)(s + \lambda_1 + \varphi_4 + \lambda_4 \varphi_4)} \right] \right\} \\ + \left[\frac{\lambda_3 \lambda_4 (s + \lambda_1 + \varphi_4)}{(s + \lambda_1 + \lambda_2 + \varphi_4)(s + \lambda_1 + \varphi_4 + \lambda_4 \varphi_4)} \right] + \left[\frac{\lambda_1 (s + \lambda_1 + \varphi_2)}{(s + \lambda_1 + \lambda_5 + \varphi_1)(s + \lambda_1 + \varphi_2 + \lambda_2 \varphi_2)} \right] + \left[\frac{\lambda_2 \lambda_4 (s + \lambda_1 + \varphi_2)}{(s + \lambda_1 + \lambda_3 + \varphi_2)(s + \lambda_1 + \varphi_2 + \lambda_2 \varphi_2)} \right] \\ + \left[\frac{\lambda_2 (s + \lambda_4 + \varphi_3)}{(s + \lambda_3 + \lambda_5 + \varphi_2)(s + \lambda_4 + \varphi_3 + \lambda_3 \varphi_3)} \right] + \left[\frac{\lambda_2 \lambda_3 (s + \lambda_4 + \varphi_3)}{(s + \lambda_4 + \lambda_1 + \varphi_3)(s + \lambda_4 + \varphi_3 + \lambda_3 \varphi_3)} \right] \quad (64)$$

$$\bar{P}_{down}(s) = 1 - \bar{P}_{up}(s)$$

3.2 Analytical Study of The Model for Particular Case

3.2.1 Availability analysis

Setting, $S_{\mu_0}(s) = \bar{S}_{\exp[x^\theta + \{\log \varphi(x)\}^\theta]^{1/\theta}}(s) = \frac{\exp[x^\theta + \{\log \varphi(x)\}^\theta]^{1/\theta}}{s + \exp[x^\theta + \{\log \varphi(x)\}^\theta]^{1/\theta}}$, $\bar{S}_{\varphi_s}(s) = \frac{\varphi_s}{s + \varphi_s}$, and

taking the values of different parameters as $\lambda_1=0.15$, $\lambda_2=0.17$, $\lambda_3 = 0.16$, $\lambda_4 =0.13$, $\lambda_5 =0.20$ $\varphi_1 = \varphi_2 = \varphi_3 = \varphi_4 = \varphi_5 = 1$, $\theta = 1$, $x = 1$, in (64), and then taking the inverse Laplace transform, one can obtain, the expression for availability as:

$$\bar{P}_{up}(t) = \left\{ \begin{array}{l} 0.04548699885e^{-2.855325039t} - 0.03115366730e^{-1.819560769t} - 0.001192469203e^{-1.364203568t} \\ -0.001528527453e^{-1.339681130t} + 0.002180442771e^{-1.166194291t} + 0.002409502930e^{-1.013719764t} \\ -0.003580857337e^{0.9828216940t} + 0.0007100044913e^{-0.97736298965t} + 0.986681056e^{-0.0331638499t} \end{array} \right\} \quad (65)$$

For, different values of time variable $t= 0, 1, 2, 3, 4, 5, 6, 7, 8, 9$.units of time, we get different values of $P_{up}(t)$ with the help of expression (65) as shown in Table 1.

Table 1: Variation of Availability with respect to time (t)

Time(t)	Availability
0	1.000
1	0.951
2	0.922
3	0.893
4	0.864
5	0.835
6	0.808
7	0.782
8	0.756
9	0.732

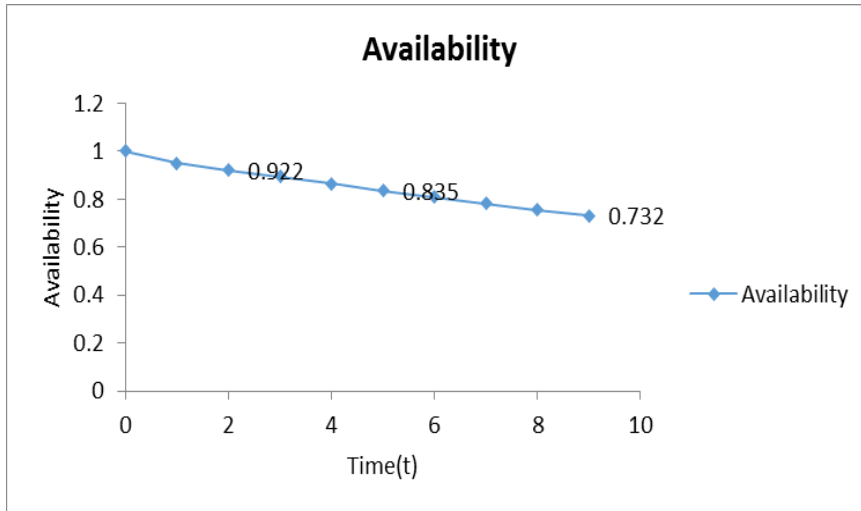

Figure1: Availability with respect to time (t)

3.2.2 Reliability Analysis

Taking all repair rates i.e. $\varphi_1(x)$, $\varphi_2(x)$, $\varphi_3(x)$, $\varphi_4(x)$, and $\mu_0(x)$ in equation (64) to zero and for same values of failure rates as $\lambda_1=0.15$, $\lambda_2=0.17$, $\lambda_3 = 0.16$, $\lambda_4 = 0.13$, $\lambda_5 = 0.20$, $\varphi=1$, $\theta = 1$, $x = 1$, and then taking inverse Laplace transform, one can get the expression reliability of the system as represented in equation (66) given as:

$$R(t) = \left\{ \begin{array}{l} 0.3409090909e^{-0.3700000000t} - 0.4051479409e^{-0.8100000000t} + 0.3777777778e^{-0.3600000000t} \\ +0.044200000000e^{-0.3100000000t} + 0.33333333 - 0.3300000000t - 0.269696967e^{-0.1500000000t} \\ +0.03923076923e^{-0.1600000000t} \end{array} \right\} \quad (66)$$

For, different values of time $t= 0, 1, 2, 3, 4, 5, 6, 7, 8, 9..$, units of time, one may get different values of Reliability that shown in Table 2. and graphical representation in Figure.

Table 2: Computation of Reliability for different values of time (t)

Time(t)	Reliability
0	1.000
1	0.856
2	0.690
3	0.542
4	0.421
5	0.327
6	0.255
7	0.199
8	0.157
9	0.125

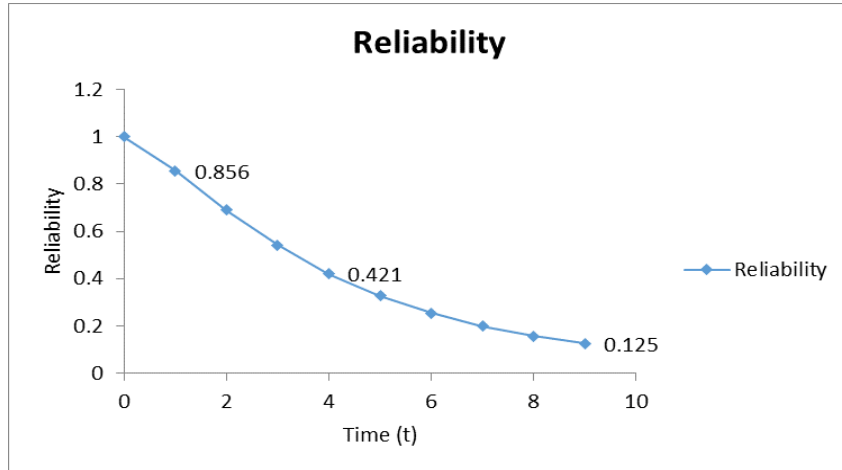

Figure 2: Reliability as a function of time (t)

3.2.3 Mean Time to Failure (MTTF) Analysis

Taking all repairs zero in equation (64), and the limit, as s tends to zero we obtain

the expression for MTTF as:

$$MTTF = \lim_{s \rightarrow 0} \bar{P}_{up}(s) = \frac{1}{\lambda_1 + \lambda_2 + \lambda_3 + \lambda_4 + \lambda_5} \left\{ 1 + \frac{\lambda_1}{\lambda_2 + \lambda_5} + \frac{\lambda_1 \lambda_2}{\lambda_3 + \lambda_4} + \frac{\lambda_3}{\lambda_4 + \lambda_5} + \frac{\lambda_3 \lambda_4}{\lambda_1 + \lambda_2} + \frac{\lambda_4}{\lambda_1 + \lambda_5} + \frac{\lambda_2 \lambda_4}{\lambda_1 + \lambda_3} + \frac{\lambda_2}{\lambda_3 + \lambda_5} + \frac{\lambda_2 \lambda_3}{\lambda_1 + \lambda_4} \right\} \quad (67)$$

Setting $\lambda_1=0.15$, $\lambda_2=0.17$, $\lambda_3 = 0.16$, $\lambda_4 = 0.13$, $\lambda_5 = 0.20$ and varying λ_1 , λ_2 , λ_3 , λ_4 and λ_5 one by one respectively as, 0.1, 0.2, 0.3, 0.4, 0.5, 0.6, 0.7, 0.8, 0.9, in (67), one may obtain the variation of M.T.T.F. with respect to failure rates as shown in adjacent Table 3 & corresponding Figure 4.

Table 3: Variation of MTTF Corresponding to The Values of Failure Rates.

Failure Rate	MTTFλ1	MTTFλ2	MTTFλ3	MTTFλ4	MTTFλ5
0.1	5.620	4.826	5.015	4.780	6.234
0.2	4.399	4.794	4.720	4.93	4.794
0.3	4.033	4.823	4.637	5.211	3.936
0.4	3.872	4.870	4.617	5.479	3.356
0.5	3.788	4.921	4.622	5.723	2.933
0.6	3.740	4.972	4.637	5.939	2.610
0.7	3.712	5.019	4.657	6.130	2.354
0.8	3.694	5.062	4.679	6.300	2.145
0.9	3.684	5.102	4.700	6.451	1.971

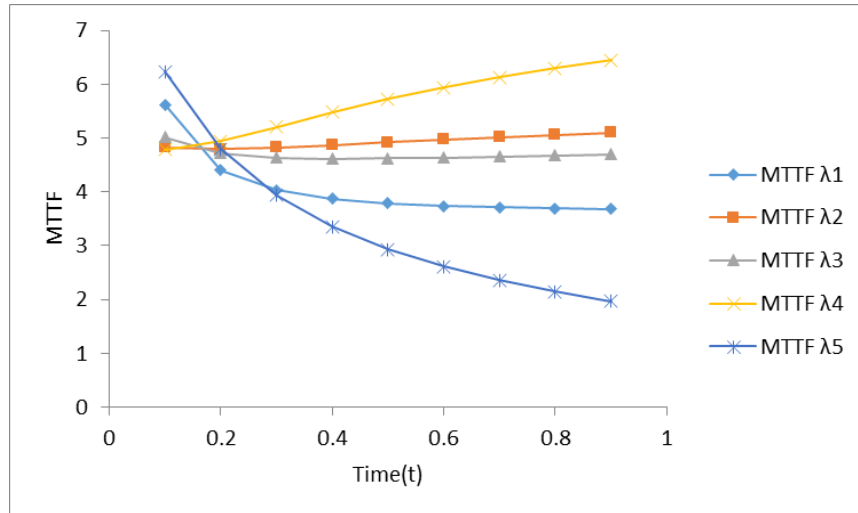

Figure 3: Variation of MTTF with Respect to Failure Rates

3.2.4 Sensitivity Analysis of (MTTF):

The sensitivity in MTTF of the system can be studied through the partial differentiation of MTTF concerning the failure rates of the system. By employing the set of parametric values of the failure rates after partial differentiation of MTTF with respect to failure rates and then varying $\lambda_1=0.15$, $\lambda_2=0.17$, $\lambda_3=0.16$, $\lambda_4=0.16$ and $\lambda_5=0.20$ in resulting expression, one can calculate the MTTF sensitivity as shown in Table 4 and the corresponding graphs are shown in Figure.4.

Table 4: Sensitivity of MTTF as a Function of Failure Rates

Failure Rate	$\frac{\partial(MTTF)}{\lambda_1}$	$\frac{\partial(MTTF)}{\lambda_2}$	$\frac{\partial(MTTF)}{\lambda_3}$	$\frac{\partial(MTTF)}{\lambda_4}$	$\frac{\partial(MTTF)}{\lambda_5}$
0.1	-25.191	-0.919	-5.666	-0.528	-19.480
0.2	-5.764	0.095	-1.430	2.554	-10.705
0.3	-2.280	0.414	-0.417	2.767	-6.905
0.4	-1.120	0.505	-0.042	2.566	-4.880
0.5	-0.616	0.512	0.116	2.295	-3.659
0.6	-0.361	0.488	0.184	2.032	-2.858
0.7	-0.220	0.453	0.211	1.799	-2.301
0.8	-0.136	0.416	0.217	1.597	-1.896
0.9	-0.084	0.380	0.214	1.423	-1.592

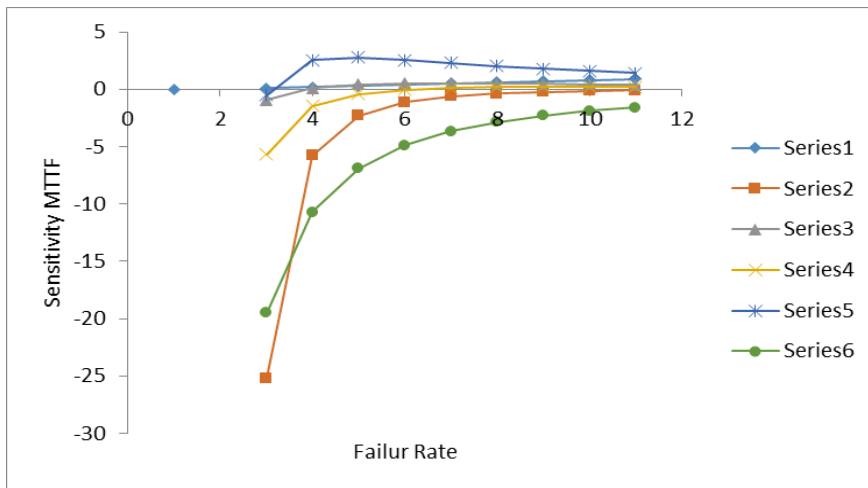

Figure 4: MTTF Sensitivity with Respect to Failure Rates.

3.2.5 Cost/Profit Analysis

If the service facility is always available, then the expected profit during the interval $[0, t)$ can be calculated by the formula given as: $E_p(t) = K_1 \int_0^t P_{up}(t)dt - K_2t$, as notation explained in section 2. For the same set of the parameter of failure and repair rates in (64), one can obtain the expression.

$$E_p(t) = \left\{ \begin{array}{l} -0.01593058521e^{-2.855325039t} + 0.0171215316562e^{-1.819560769t} + 0.0011409636636e^{-1.339681130t} \\ -0.001869707979e^{-1.16619429t} - 0.002376892525e^{-1.013719764t} + 0.003643445560e^{-0.9828216940t} \\ -0.00072923448800e^{-0.9736298965t} + 29.75131463e^{-0.03316384899t} + 29.74944100 \end{array} \right\} \quad (68)$$

Setting $K_1= 1$ and $K_2= 0.6, 0.5, 0.4, 0.3, 0.2$ and 0.1 respectively and varying $t=0, 1, 2, 3, 4, 5, 6, 7, 8, 9$. Units of time, the results for expected profit can be obtained as shown in Table 5 and graphical representation in Figure.6.

Table 5: Expected Profit in $[0,t)$ $t=0,1, 2, 3, 4 \dots 9$

Time (t)	$E_p(t):$ $K_2=0.6$	$E_p(t):$ $K_2=0.5$	$E_p(t):$ $K_2=0.4$	$E_p(t):$ $K_2=0.3$	$E_p(t):$ $K_2=0.2$	$E_p(t):$ $K_2=0.1$
0	0.000	0.000	0.000	0.000	0.000	0.000
1	0.370	0.470	0.570	0.670	0.770	0.870
2	0.707	0.907	1.107	1.307	1.507	1.707
3	1.015	1.315	1.615	1.915	2.213	2.515
4	1.294	1.694	2.094	2.494	2.894	3.294
5	1.544	2.044	2.544	3.044	3.544	4.044
6	1.766	2.366	2.966	3.566	4.166	4.766
7	1.961	2.661	3.361	4.061	4.761	5.461
8	2.131	2.931	3.731	4.531	5.331	6.131
9	2.275	3.175	4.075	4.975	5.875	6.775

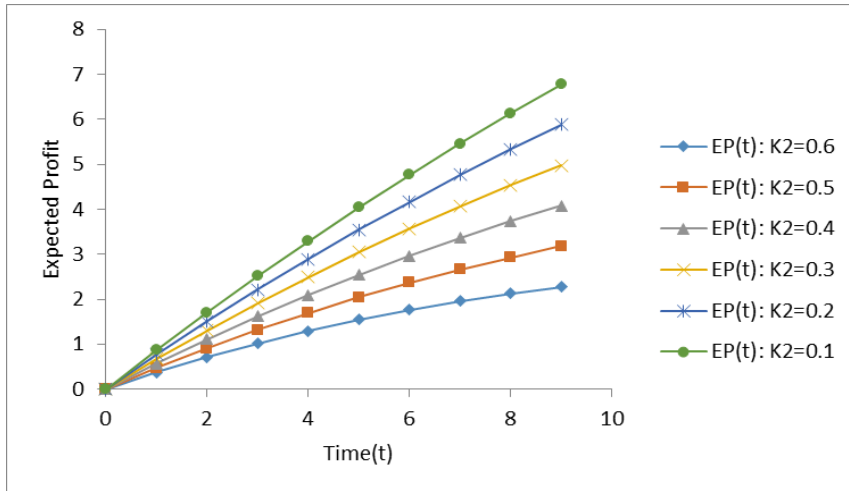

Figure 5: Expected Profit as Function of Time (t)

4 Result analysis and conclusions

For the interpretation, assessment, and performance of the system under consideration of reliability measures for different values of failure and repair rates. Table.1 provides information of availability of the complex repairable system with respect to the variation in time when the failure rates are fixed at different values particularly, $\lambda_1=0.15, \lambda_2=0.17, \lambda_3=0.16, \lambda_4=0.16$ and $\lambda_5=0.20$. The availability of the system decreases slowly, and the probability of failure increases, with the passage of time and ultimately becomes steady to the value zero after a sufficiently long interval of time. Hence, one can safely predict the future behavior of a complex system at any stage for any given set of parametric values, as shown by graphical consideration of the model in Figure 1.

Table. 2 assesses the reliability of system when the repair is ignored. Evidently, by comparison, the values of availability and reliability in table 1 & table2 it is shown that when the repair is provided the performance of the system is quite better.

Table.3, provide the information of mean time to system failure (MTTF) in respect of variation of the values of failure rates. The change in the values of MTTF is

directly associated with system reliability. The computations MTTF for different values of failure rates, $\lambda_1, \lambda_2, \lambda_3, \lambda_4$ and λ_5 and the graphical representation is shown in Figure 3 help to design more reliable system. The variation in MTTF corresponding to failure rates λ_1, λ_2 is high compared to another failure which indicates that system will not be affected with higher variations in values λ_1 & λ_2 . The MTTF due to λ_5 will influence the operation of the system as the value of MTTF is lower corresponding to λ_5 .

Table. 4 and the corresponding Figure 4, shows the variation of sensitivity with a change in the values of parameters.

Finally, by fixed revenue cost per unit time $K_1= 1$, and varies the service costs $K_2 = 0.6, 0.5, 0.4, 0.3, 0.2$ and 0.1 , the profit has been calculated, and graphs demonstrate results in Figure 5. A critical examination of Figure.5 reveals that the expected benefit increases concerning the time one can observe that as service cost increase, profit decrease. In general, for low service cost, the expected profit is high in comparison to high service cost.

ACKNOWLEDGEMENTS. Authors are grateful to reviewers for their constructive and meaningful suggestions to improve the paper.

References

- [1] Alka Munjal and S. B. Singh, Reliability analysis of a complex repairable system composed of two 2-out-of-3: G subsystems connected in parallel, *Journal of reliability and statistical studies*, **7** (Special Issue), (2014), 89-111.
- [2] V. V. Singh, Jyoti Gulati, D. K. Rawal and C. K. Goel, Performance analysis of complex system in series configuration under different failure and repair

- discipline using copula, *International Journal of reliability quality and safety engineering*, **23**(2), (2016), 1-21.
- [3] W. K. Chung, Reliability analysis of a K-out-of-N redundant system with the presence of chance with multiple critical errors, *Microelectron. Reliability*, **33**, (1993), 331-334.
- [4] B.S. Dhillon and O.C. Anude, Common cause failure analysis of a K-out-of-N: G system with repairable unit, *Microelectronics Reliability*, **34**(3), (1994), 429-442.
- [5] L. R. Goel, and P. Gupta, Analysis of a K-out-of-N unit system with two types of failure and preemptive maintenance, *Microelectron. Reliability*, **24**(5), (1984), 877-880.
- [6] S.P. Jain and K. Gopal, Reliability of 1- out – of - N systems, *Reliability Engineering*, **12**, (1985), 175-179.
- [7] Ibrahim Yusuf, Availability modeling and evaluation of a repairable system subject to minor deterioration under imperfect repairs, *International journal Mathematics in Operational Research*, **7**(1), (2015), 45-51.
- [8] Minjae Park, Warranty cost analysis for multi- component systems with imperfect repair, *International Journal of Reliability and Applications*, **15**(1), (2014), 51-64.
- [9] Deepak Kumar and S.B Singh, Stochastic analysis of complex repairable system with deliberate failure emphasizing reboot delay, *Communications in Statistics-Simulation and Computations*, **45**(2), (2016), 583-602.
- [10] M.S. Kadyan, Ram Niwas and Jitender Kumar, Probabilistic analysis of two Reliability models of a single-unit system with preventive maintenance beyond warranty and degradation, **17**(4), (2015), 535-543.
- [11] V.V. Singh, S.B. Singh, Mangey Ram and C. K. Goel, Availability analysis of system having three unit's super priority, priority and ordinary under primitive resume repair policy, *International Journal of Reliability and Applications*, **11**(1), (2010), 41-53.

- [12] V. V. Singh and Mangey Ram, Multi-state k-out-of-n type system analysis, *Mathematics in Engineering, Science, and Aerospace*, **5**(3), (2014), 281-292.
- [13] Dilip Kumar Rawal, M. Ram and V. V. Singh, Modeling and Availability analysis of internet data center with various maintenance policies, *International Journal of Engineering, Transaction A: Basics*, **27**(4), (2014), 599-608.
- [14] V. V. Singh, Chiwa Musa Dalah, Study of reliability measures of a two-unit standby system under the concept of switch failure using copula distribution, *American Journal of Computational and Applied Mathematics*, **4**(4), (2014), 118-129.
- [15] Tseng- Chang Yen, Wu- Lin Chen and Jia-Yu Chen, Reliability and sensitivity analysis of the controllable repair system with warm standby and working breakdown, *Computers and Industrial Engineering*, **97**(3), (2016), 84-97 .
- [16] R. B. Nelsen, *An Introduction to Copulas*, 2nd ed., Springer Publishers, New York, 2006.