

# Conical Slot Antenna for Air and Sea Vehicle Applications

Irene Karanasiou<sup>1</sup>, Michael Gargalacos<sup>2</sup>, Panagiotis Farantatos<sup>3</sup>,

Grigorios Stromatias<sup>4</sup>, Ioannis Vafakis<sup>5</sup>, Spiridon Gotzias<sup>6</sup>,

Ioannis Chalkiadakis<sup>7</sup>

## Abstract.

Antennas constitute a decisive component of all communications abilities. The development of ground, air, sea, and space-based antennas must totally comply with the state-of-the-art and beyond advances in vehicle communications systems. Mobility, bandwidth demands, gain and radiation efficiency as well as low cost and simple integration are requirements that need to be met concurrently. In cases where conformality is also a prerequisite, planar and slot antennas prove to be optimal solutions. In this context, a conical slot antenna for vehicle applications at VHF-UHF operation frequencies is presented. The simulation and the measurement results show that the proposed slot antenna provides efficient radiation pattern while being lightweight, low cost and simple to manufacture and integrate.

**Keywords:** Conical slot antenna, VHF-UHF, security and civil protection applications.

## 1. Introduction

Modern communication systems being envisaged and developed to sustain adaptable, highly networked operations, are without a doubt setting constantly

---

<sup>1</sup> Dep. of Mathematics & Engineering Sciences, Hellenic Military Academy, Vari – 16673, Athens, Greece,

E-mail: [ikaran@esd.ece.ntua.gr](mailto:ikaran@esd.ece.ntua.gr)

<sup>2</sup> Dep. of Mathematics & Engineering Sciences, Hellenic Military Academy, Vari – 16673, Athens, Greece,

E-mail: [michel@esd.ece.ntua.gr](mailto:michel@esd.ece.ntua.gr)

<sup>3</sup> School of Electrical and Computer Engineering, National Technical University of Athens, 9, Iroon Polytechniou 15780, Zografos Campus, Greece

<sup>4</sup> Second Lieutenant Hellenic Army

<sup>5</sup> Second Lieutenant Hellenic Army

<sup>6</sup> Second Lieutenant Hellenic Army

<sup>7</sup> Second Lieutenant Hellenic Army

performance requirements for antenna subsystems. The latter are a decisive component of all communications abilities including civil protection, security and military applications. The development of Ground, Air, Sea, and Space-based antennas must adhere with the advances in software radios, vehicle communications systems and satellite communications ([1]).

Some of the aspects of antenna research in the aforementioned applications include the design of special antennas to meet mobility as well as military bandwidth demands ([1]). Research for solutions to integrate apertures suitable for most microwave RF functions in conjunction for research for ways to reduce and overcome threats from interference and jamming is always ongoing. Finally, hot topics are all economic aspects comprising cost effective production, modification and maintenance procedures for civil and military antenna systems ([1]).

In parallel, there is significant interest in broadband antennas-with frequencies ranging from below 30 MHz to over 6 GHz - that can become conformal and then be mounted on the surface of land, air, and sea vehicles ([2]). Other additional parameters that should be taken into account are for example aperture size which is frequently limited to considerably less than optimal while maximum gain and pattern coverage are still main prerequisites for successful use and implementation ([2]).

Especially when conformal antennas are needed in cases where the friction forces must be eliminated, printed and slot antennas prove to be the most suitable solutions allowing at the same time for extended load capability due to their light weight. They also have very attractive features in terms of gain and radiation efficiency, while they are also low cost, low profile, and simple to integrate ([3], [4], [5]).

Currently, unmanned aerial vehicles (UAV) are broadly being used for exploration and surveillance as well as in military applications. Commonly, their role is to collect data via appropriate sensor systems and communicate them wirelessly to a central station. Regarding choosing the best location for the installation of communication antennas on UAVs many tests have been carried out over the years investigating all possible places. It seems that the optimum location differs according to the application. The nose, the fins and the wings have been proposed each one presenting specific advantages. The nose provides less space and is more suited for directional antennas. On the other hand the wings provide more mounting space and therefore

there is a greater pool of suitable antennas that could be used. The final decision of where to place the antenna on the UAV is a complex one taking into accounts both the application and the flight aerodynamics of the whole vehicle ([6]).

Finally, airborne ultra-wideband radar systems require reception antennas that are conformal or can be positioned onto wings for instance ([5]). They also need to operate at low frequencies such as VHF and often must be mounted in such a way to face to the side of the vehicle. Tapered slot antennas are suitable for this purpose ([7], [8]).

In this context and taking all of the aforementioned into account, a conical slot antenna for unmanned vehicle use, implementing a wide range of applications at VHF-UHF operation frequencies is presented in the next sections.

## 2 Theoretical Background

UAVs have specific operational requirements which make all the mechanical and electronic parts with which they are equipped especially designed. The same applies for the antennas used in UAVs and are deployable on its wings. These antennas should meet specific characteristics which are linked both to the flight characteristics of the UAV (e.g. tilt of the wing) and to the operational characteristics of the communication link that will be supported by the UAV (e.g. frequency band used). Summarizing the main attributes of such an antenna the following could be mentioned:

1. The antennas should be conformal and flexible in order to withstand the tilt of the wing.
2. They must be mounted or even better printed on the wing.
3. They should be able to operate at the whole range of VHF –UHF frequencies.
4. Depending on the operational requirements antennas need to have high gain, directional radiation pattern and acceptable input impedance

A number of antennas fulfilling the above mechanical characteristics and operating in the VHF-UHF frequency range has been extensively investigated in literature ([9]). Half-wave dipole and Yagi-Uda antennas are easy to build and mount, low cost, but their operational characteristics do not reach as low as VHF frequencies. Bow-tie

antennas have also interesting characteristics, but there are not broadband for the whole VHF-UHF frequency range and in addition their radiation pattern presents significant side lobes which could create jamming problems if more than one of these antennas is to be used.

Similar to the previous is the Maltese cross antenna which also has the advantage of being able to receive horizontal, vertical or circular polarization. This type of antenna has been mainly used in GPS satellite and DCS 1800 personal systems and thus its operational characteristics at VHF frequencies are questionable.

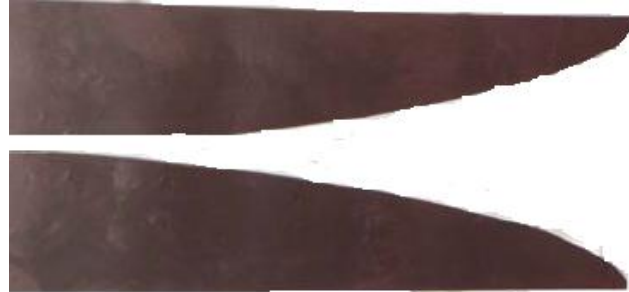
Another category of antennas suitable for being mounted on UAV wings are branch line planar antennas which have a great variety of applications due to their adjustable shape and frequency of operation. They have been used in mobile phones for reducing their overall volume, but at the same time their radiation characteristics could be efficient at the lower parts of the VHF range, an attribute that makes them one of the few candidates for UAVs, given the UAV's wing size restrictions ([9]). They can make use of the whole area of the wing as their design could be modified according to the wing shape and structure, but their radiation pattern is such that if more than one of them is used they may interfere with each other. This fact renders them undesirable for certain UAV applications.

On the other hand, slot antennas have high gain, their construction and mounting on the UAV's wings is simple and their radiation pattern is directional, while their back lobes are suppressed, a fact that permits use of two of them in a back to back configuration for both UAV's wings with minimum interference risks. Concluding the slot antenna seems to have some of the most promising characteristics for UAV usage and therefore it will be investigated furthermore in this paper.

### **3 Modeling of Slot Antenna**

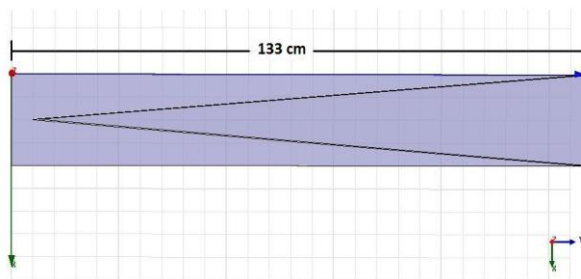
A slot antenna is made of a flat metallic plane, in other words a metal surface comprising a hole or slot cut out. When the plane with the cuts in question is driven as an antenna at a specific operating frequency, the slot radiates electromagnetic waves resembling to the way a dipole antenna radiates (e.g. Figure 1). The shape and size of

the slots and their position on the metal surface, determine the antenna operation frequency and radiation distribution pattern.

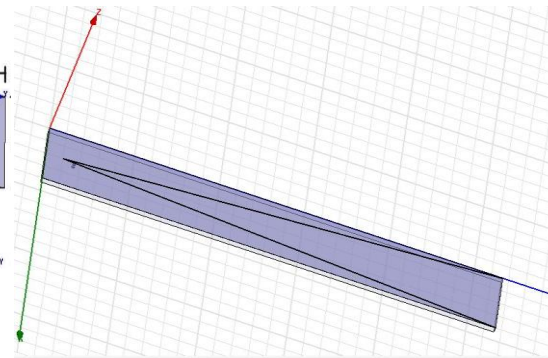


**Figure 1.** Example of a tapered slot antenna, the Vivaldi antenna

The proposed slot antenna is depicted in Figure 2. The antenna dimensions are 133cmx20cm and the slot, which is shaped like the Greek letter “lambda”, forming a conical slot antenna, is 2mm thick. The antenna is made from 1mm thick copper and the substrate used in the simulations is air. In Figure 3, a magnification of the slot used can be observed.

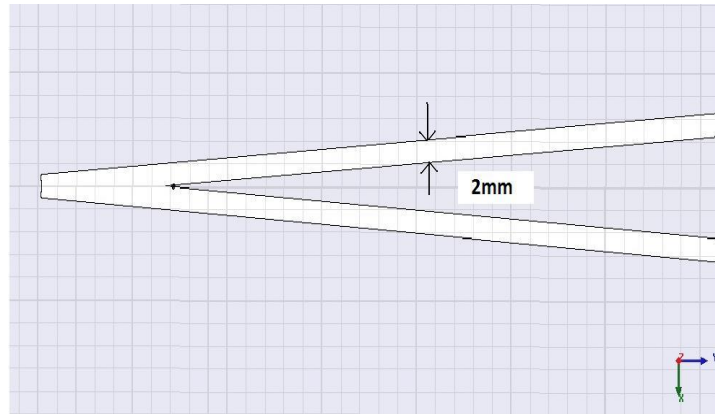


**Figure 2a.** Model of proposed slot antenna



**Figure 2b.** Model of proposed slot antenna  
(side view)

The three dimensional model used for the simulations is shown in Figure 2. After the model setup, the air box and appropriate boundary conditions were set and meshing was performed. Following, the sweep frequency parameters setup took place and finally the simulation results were viewed and plotted.

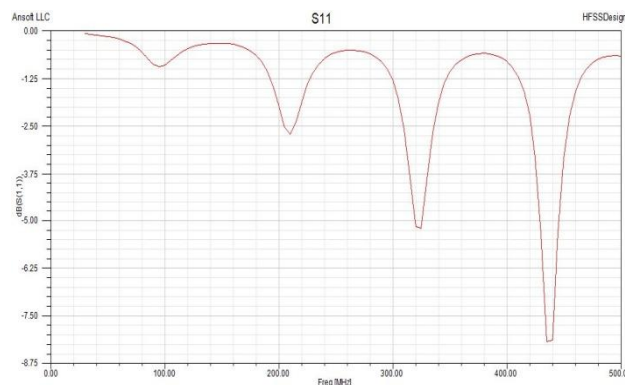


**Figure 3.** Magnification of Figure 1 where the exact geometry and dimensions of the slot can be observed.

The analysis of the electromagnetic problem is approached numerically using commercial simulation software (High Frequency Structure Simulator, HFSS, Ansoft Corporation). HFSS solves Maxwell's equations using a finite element method, in which the solution domain is divided into a set of tetrahedral elements, termed as "mesh." The characteristics of the generated mesh are crucial to obtaining a reliable, well-converged solution ([10]).

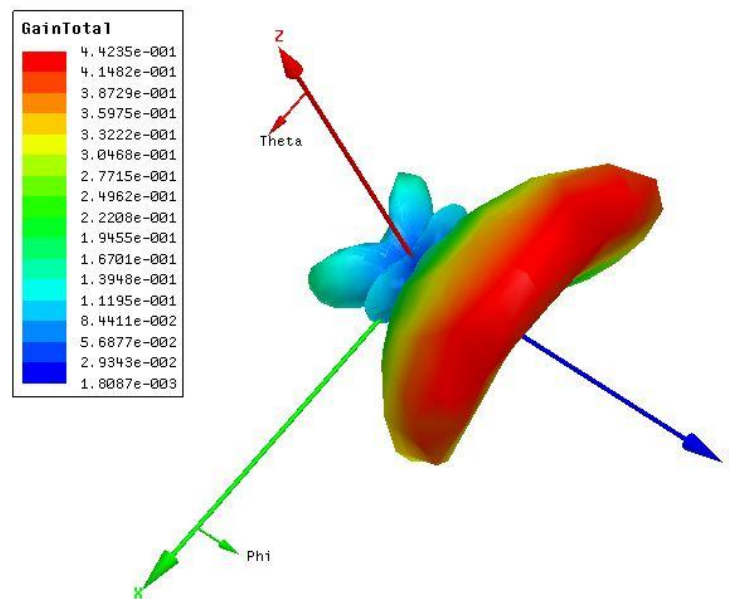
## 4. Simulation Results

After performing simulations using sweep frequency setups over the whole frequency bandwidth of 30-500MHz, the S11 parameter values and the antenna radiation pattern were calculated.



**Figure 4.** S11 values over the whole operation bandwidth 30-500MHz

As it can be observed in Figure 4, multiple resonant frequencies are achieved over the whole bandwidth with the most efficient S11 value of -8dB is reached at 400-450MHz. The radiation pattern is shown in Figure 5. The back side lobes are suppressed and the antenna radiates above, below and at the side. As we have already mentioned the fact that the back side lobes are suppressed is very important for our application since two of these antennas mounted on each UAV wing will be used and therefore back side radiation could create significant jamming problems. Based on the simulations results this potential problem has been overcome.



**Figure 5.** Three dimensional far field radiation pattern of the proposed slot antenna

## 5. Measurements

Following the simulation results, the proposed antenna was developed at a 1:5 scaling. The scaling was chosen in order to facilitate both the antenna construction and the subsequent measurements. Two identical models of the antenna were developed and were placed on Plexiglas in order to achieve better mechanical stability and at the same time facilitate the laboratory measurements. It should be noted that the dielectric permittivity ( $\epsilon_r$ ) of the Plexiglas material is very close to 1, something which is consistent with the simulating analysis in which the substrate of the antenna was assumed to be open air ( $\epsilon_r=1$ ).

The final scaled dimensions of the antenna were 27cmX 4cm and the measuring range was set to 5 times the simulation range (30MHz X 5-500MHz X 5). The model of the developed antenna is shown in Figure 6. It should be noted that the final construction is slightly different than the one used for the simulations. The reason is that during the measurements the edges of the “lambda” construction were cut symmetrically in order to achieve a better tuning range for the antenna. So the antenna was finally given a triangular shape which resulted in a better resonance in the frequency range of interest.



**Figure 6.** The printed slot antenna in a 1:5 scale

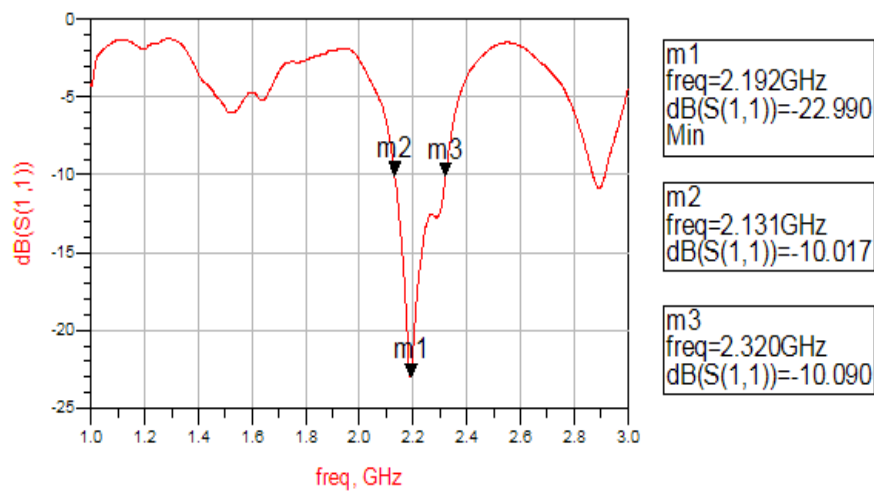
Measurements were carried using the HP 8510C network analyzer at the 150MHz-2.5GHz frequency range. At first the S11 parameter of the antenna was measured and the results are shown in figure 7. In this figure the window for the frequency range has been narrowed down to 1GHz-3GHz, corresponding to an actual frequency range of 200MHz-600MHz in which the antenna had a better performance according to the simulation results.

Comparing the results of figure 7 with Figure 4 we can observe that there are almost identical. More specifically a primary resonance in the range 2.1-2.3 GHz (-10 db) of the scaled antenna is observed, which is equivalent with a frequency range 420 MHz-460 MHz of the simulated antenna. A secondary resonance is also observed in the 1.5 GHz frequency range, which is equivalent with the 300 MHz tuning of the simulated antenna.



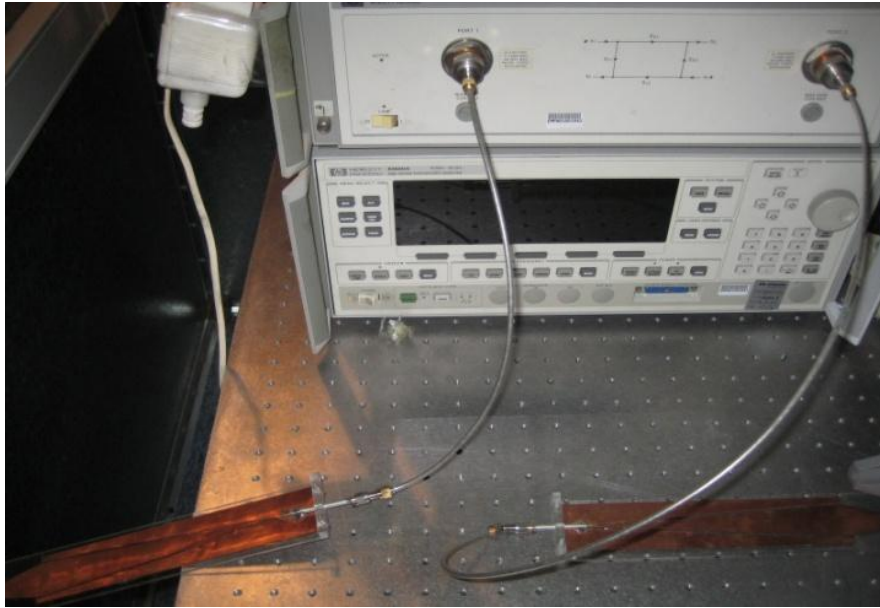
Another secondary resonance is also observed at the beginning of the diagram (1GHz, -5db) which is also consistent with the 200MHz secondary tuning of the simulated antenna. In the area below the 200MHz range and as low as the VHF frequencies, both the simulations carried out and the subsequent measurements have shown that the antenna performance is acceptable but not as good and as efficient as at the UHF band.

Following the measurement of S11 the two identical antennas were placed in a back to back configuration in order to measure the coupling between them. Each antenna was connected to one port of the network analyzer and the S12 parameter was measured at a distance of 5cm between them. This 5cm distance corresponds to a physical distance of 25 cm according to the 1:5 scaling. As we have already mentioned one of the possible applications of this antenna is its usage on UAVs. The proposed configuration is to use two identical antennas which will be placed and operated below the UAV's wings. In this case the interference from one antenna to the other through their side and back lobes has to be measured and estimated for the effect that will have to the overall performance of the system

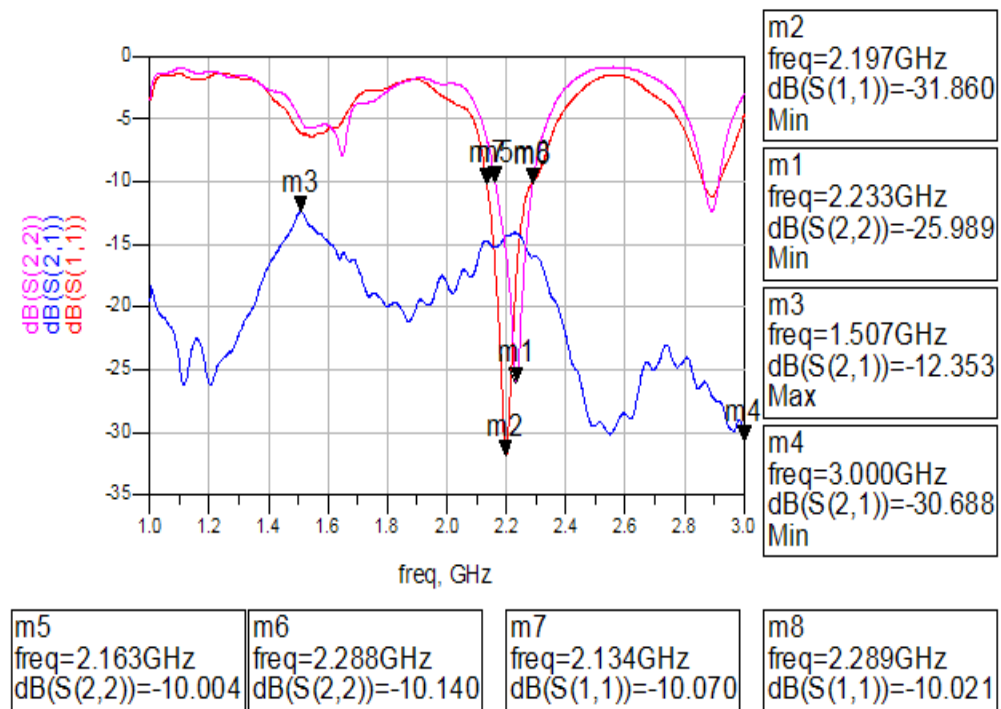


**Figure 7.** The S11 parameter of the printed antenna

The measurement configuration for the coupling is shown in Figure 8 and the measurements results of S11, S22 and S12 is shown in Figure 9.



**Figure 8.** Setup for the measurement of the coupling between the two identical slot antennas



**Figure 9.** Experimental results of S11, S22 and S12 for both slot antennas

The reflection coefficients  $S_{11}$ ,  $S_{22}$  of both antennas were measured again verifying the results of Figure 7. It is obvious from figure 9 that both antennas exhibit identical performance which was also expected. The  $S_{12}$  parameter (coupling coefficient) was found below -12db for the whole frequency range of interest and below -15db for the largest part of it. This result shows that if a couple of this type of slot antennas was used in applications with UAVs there would be no severe interference between them and therefore this antenna is suitable for these types of applications. In Figure 10 we can observe the proposed configuration for the placement of the antenna under a sample of UAV wing. This is an experimental setup in which the antenna material used is aluminum foil. In a later stage the same configuration will be applied on another wing using copper material.



**Figure 10.** Mounting of the antenna on the wing

## 6 Discussion and Conclusion

A slot antenna for vehicle applications is presented in this paper. The antenna operates at VHF-UHF frequencies and is extremely low cost and lightweight. Antenna resonant and radiation pattern characteristics are efficient as simulation and measurement results have showed.

In the near future, the proposed antenna will be tested using various feeding and slot dimensions schemes both in simulation and experiment. In addition preliminary testing has shown that the performance of the antenna can be further improved if the thickness of the antenna slot is gradually modified, being thinner at the base of the antenna and wider at its edge, resembling to the Vivaldi type shown in Figure 1.

Such antennas as the one proposed, maybe used in cases where line-of-sight communication is very difficult to be achieved and carrier frequencies at the VHF-UHF ranges are commonly used. In urban environments or over irregular terrain, there is substantial penetration through foliage and concrete, wave diffraction around obstacles, and wave propagation over surfaces at these operating frequencies ([8]). At the same time though, the dimensions of efficient antennas are quite large, and therefore, lack of available space for housing might be observed in the effort to avoid the risks of mutual coupling and co-site interference ([11]).

Furthermore these types of antennas being lightweight could be ideal for UAV's applications enabling manufacturers to design more compact and lightweight UAV's resulting in reduced costs and longer operational distances. If this attribute is combined with the fact that the placement of these antennas below the UAV's wings offers a more robust construction without any external parts that could affect the aerodynamics of the whole vehicle or be easily damaged during take-off or landing, then the operational advantages of these slot antennas for UAVs usage are multiplied. Finally internal constructions such as the ones proposed reduce drag forces, a fact that prolongs the flight time and improves the operational characteristics of the UAV.

In addition, depending on the requirements, a single broadband antenna besides being bulky may even not be sufficient because the polarization and the direction of maximum directivity at different frequencies may vary. It should also be noted that any type of broadband antenna is highly vulnerable to electronic warfare jamming techniques ([10]). In consideration of the above, the proposed slot antenna seems a viable solution meeting all requirements and minimizing risks at the same time.

## References

- [1] 8th Military Antennas September 12 - 15, 2011, Washington Marriott, USA
- [2] M.W. Nurnberger, J.L. Volakis: *Extremely Broadband Slot Spiral Antenna with Shallow Reflecting Cavities*, *Electromagnetics*, 20(4)2000, pages. 357-376
- [3] M.S. Sharawi, O.A. Rawashdeh,, D.N. Aloï: *Evaluation and field testing of an embedded antenna in a small UAV wing structure*, *Radio and Wireless Symposium (RWS)*, 2010 IEEE, pp.589-592, 10-14 Jan. 2010
- [4] M.S. Sharawi, O.A. Rawashdeh,, D.N. Aloï: *2.4GHz Printed Antennas Embedded in Small UAV Wing Structures*, *Journal of Electromagnetic Waves and Applications*, 24(2010), pages 463–474
- [5] W.S. Bigelow, E.G. Farr, C.E. Baum, D.I. Lawry: *A Conical Slot Antenna and Related Antennas Suitable for Use with an Aircraft with Inflatable Wings*, *Air Force Research Laboratory Final Report*, 2005
- [6] X. Huang et al. (eds.): *Advances in Communication Systems and Electrical Engineering*. 393© Springer 2008
- [7] M, Strycek, I, Hertl, R, Pavlik, V, Polacek: *Tapered slot antennas for ground penetrating radar*, *13th International Conference on Ground Penetrating Radar (GPR)*, 2010, pages 1-4, 21-25 June 2010
- [8] H. M. Jol: *Ground Penetrating Radar: Theory and Applications*, Elsevier B. V., 2009
- [9] R. R. Tammannagari: *Design and development of structurally feasible unmanned aerial vehicles*. Master's Thesis 2010 University of Kentucky
- [10] [www.ansys.com](http://www.ansys.com)
- [11] K. Sarabandi, R. Azadegan: *Design of an Efficient Miniaturized UHF Planar Antenna*, *IEEE Transactions on Antennas and Propagation*, 51(6)(2003), pages 2531-2538.